

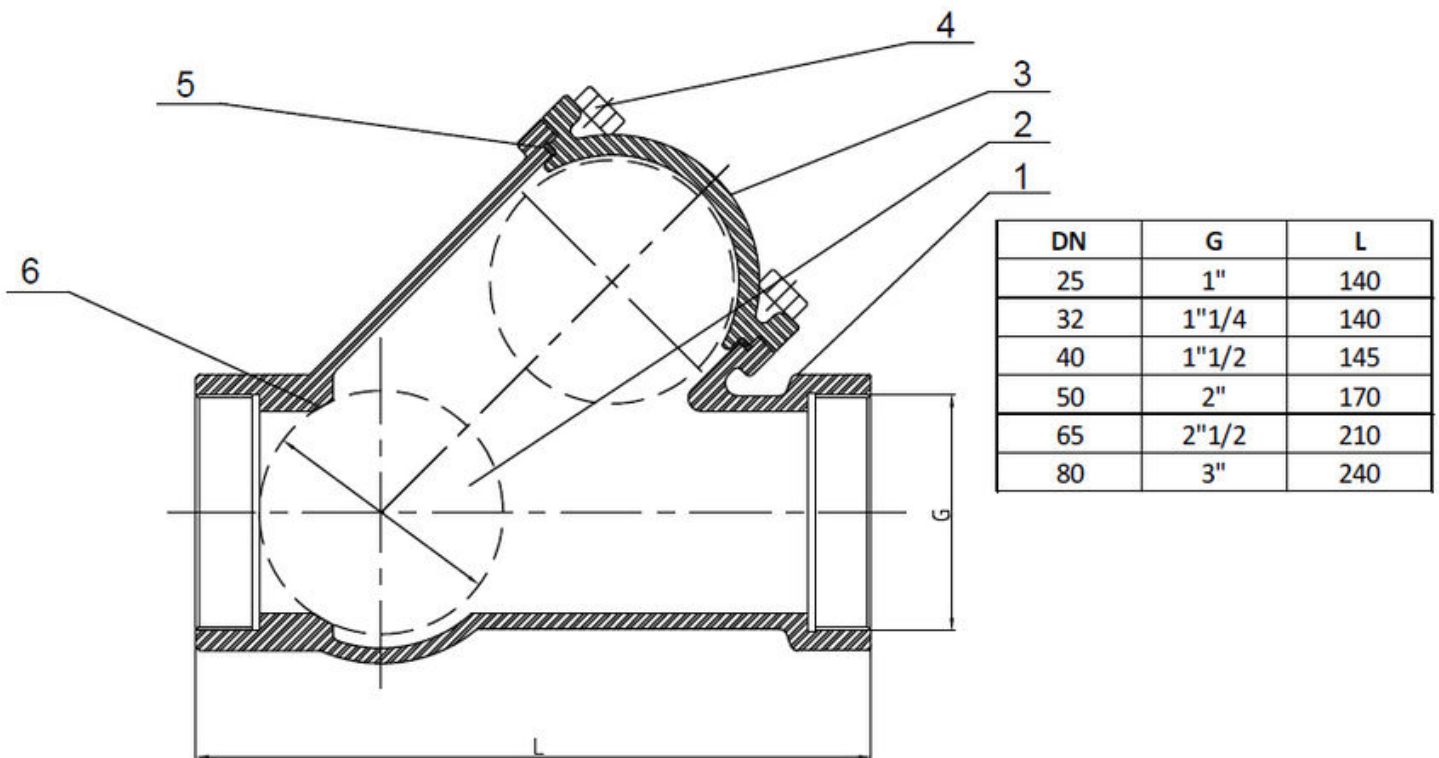

398 Cast Iron Ball Check Valve

CAST IRON BALL CHECK VALVE,
BSP FEMALE THREADED ENDS.
TECHNICAL DATA SHEET

BSP FF threads
Pressure : PN 10 bar
Temperature : -10°C / +80°C
Traceability with batch number



Item	Désignation/Description	Matière / Material	
		DN25-32-40	DN50-65-80
1	Corps / Body	Fonte ductile + epoxy / Ductile iron + epoxy	
2	Chapeau / Cap	Fonte ductile + epoxy / Ductile iron + epoxy	
3	Boule / Ball	Résine / Resin	Aluminium + NBR / Aluminum + NBR
4	Boulons / Bolts	Inox 304 / Stainless steel 304	
5	Joint plat / Flat gasket	NBR	
6	Siège / Seat	NBR	/



www.orseal.com



01204 474300

Orseal Ltd, Lynstock Way, Lostock, Bolton, Lancashire, BL6 4QR