

399 Cast Iron Ball Check Valve



Description

- Face to face acc to DIN 3203-F6
- Connection Ends: Flange to EN 1092-2
- Working Pressure: PN10/16
- Temperature range: 0° C—80° C
- Coating: Fusion Bonded Epoxy Coating in accordance with ANSI/AWWA C550
- CE marking

No	Description	Material
1	Body	EN-GJS-450-10 or EN-GJL-250
2	Ball	Aluminium Ball or steel + EPDM or NBR
3	Cover	EN-GJS-450-10 or EN-GJL-250
4	Bolt	Carbon Steel Zinc plated
5	Nut	Carbon Steel Zinc plated
6	Flat washer	Carbon Steel Zinc plated
7	O rings	NBR
8	Nut	Brass or zinc plated steel
9	Washer	EPDM
10	O rings	NBR
11	Nut	Zinc plated steel
12	Screw	Brass or zinc plated steel

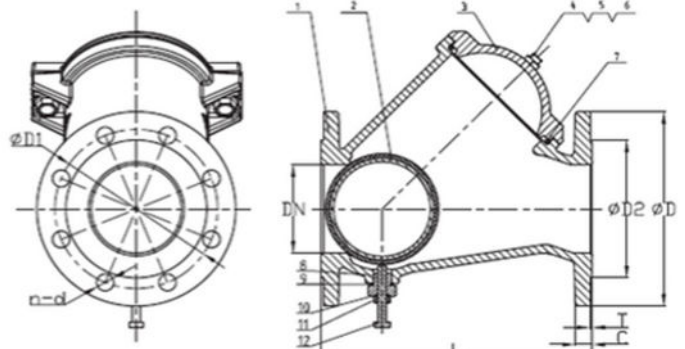

DN		PN	L	D	D1	d	C	T	n-ØL
Inch	Mm								
2"	50	10/16	200	165	125	99	19	3	4-Ø19
2.5"	65	10/16	240	185	145	118	19	3	4-Ø19
3"	80	10/16	260	200	190	132	19	3	8-Ø19
4"	100	10/16	300	220	180	156	19	3	8-Ø19
5"	125	10/16	350	250	210	184	19	3	8-Ø19
6"	150	10/16	400	285	240	211	19	3	8-Ø23
8"	200	10	500	340	295	266	20	3	8-Ø23
		16					3	12-Ø23	
10"	250	10	600	405	350	319	22	3	12-Ø23
		16			355		3	12-Ø28	
12"	300	10	700	460	400	370	24.5	3	12-Ø23
		16			410		4	12-Ø28	