



the valve specialists

## 424 Cast Iron Gate Valve



### Description

- Applications : Drinking water supply, water treatment, sewerage system, irrigation.
- Fluids : Drinking water, glycol water, non-aggressive fluids.
- Pressure : PN 10 bar
- Temperature : 0 / +120°C.
- CE : According to 2014/68/EU directive.

No	Description	Material
1	Body	Ductile Iron GGG-45/ GG-25 + blue epoxy coating
2	Body Seat	Brass
3	Gate Seat	Brass
4	Gate	Ductile Iron GGG-45/ GG-25
5	Stem	Stainless Steel
6	Bonnet Gasket	EPDM + PTFE
7	Middle Hoop	Ductile Iron GGG-45/ GG-25
8	O-ring	EPDM
9	Sealing Washer	EPDM
10	Top Hood	Ductile Iron GGG-45/ GG-25
11	Gland	EPDM
12	Packing Gland	Ductile Iron
13	Stud	Steel
14	Handwheel	Ductile Iron GGG-45/ GG-25
15	Stem Nut	Brass

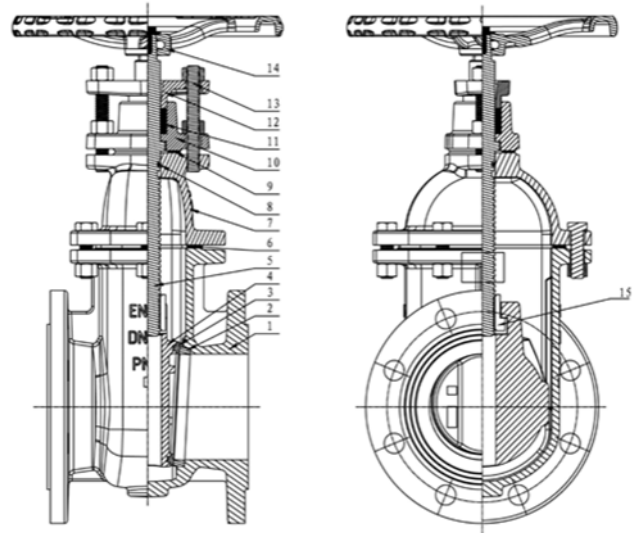

DN	GN	PN (bar)	n-ØL	L	D	D1	D	H	T	C	Weight (kg)
40	10-16	10	4-Ø19	140	150	110	84	256	3	19	12.1
50	10-16	10	4-Ø19	150	165	125	99	264	3	19	15
65	10-16	10	4-Ø19	170	185	145	118	280	3	19	19.5
80	10-16	10	8-Ø19	180	200	160	132	305	3	19	22
100	10-16	10	8-Ø19	190	220	180	156	369	3	19	32.75
125	10-16	10	8-Ø19	200	250	210	184	443	3	19	44
150	10-16	10	8-Ø23	210	285	240	211	467	3	19	55
200	10	10	8-Ø23	230	340	295	266	571	3	20	85.5
250	10	10	12-Ø23	250	405	350	319	662	3	22	127.5
300	10	10	12-Ø23	270	460	400	370	766	4	24.5	161

Orseal Ltd, Lynstock Way, Lostock, Bolton, BL6 4QR

T: +44 (0)1204474300 / F: +44 (0)1204474347

E: sales@orseal.com

W: www.orseal.com