



the valve specialists

426 Cast Iron Swing Check Valve

Description

- Pressure : PN 16 - 10 bar.
- Temperature : Max 150°C.
- Standardized flanges
- Dimensions DIN2501/1 PN10 or PN16.
- Face to Face DIN3202/1
- Certs & Tests; Hydraulic Test DIN 323



No	Description	Material
1	Body	Cast Iron EN-GJL-250
2	Seat	bronze
3	Disc	Carbon Steel C22
4	Lever	Carbon Steel C22
5	Stem Nut	Stainless Steel
6	O ring	EPDM
7	Cap	PTFE Graphite

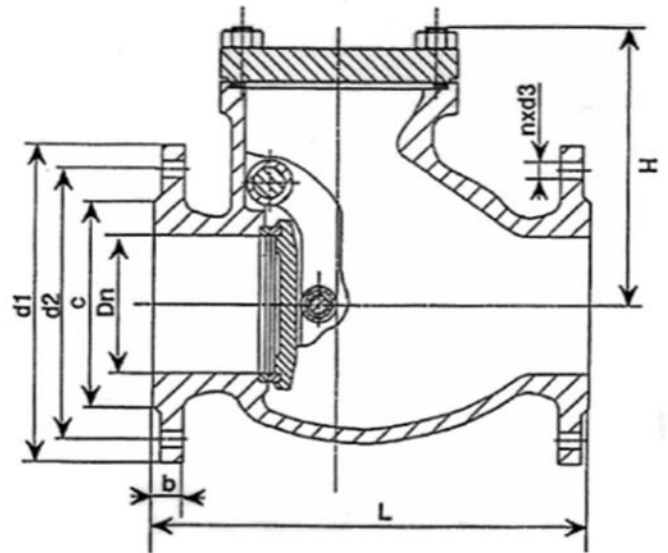

DN	PN	L	d1	d2	nxd3	C	b	H	Weight (kg)
40	16	180	150	65	4 X 18	88	18	120	12
50	16	200	165	72	4 X 18	102	20	135	15
65	16	240	185	85	4 X 18	122	20	150	20
80	16	260	200	100	8 X 18	138	22	170	28
100	16	300	220	110	8 X 18	158	24	188	41
125	16	350	250	125	8 X 18	188	24	220	69
150	16	400	285	145	8 X 18	212	24	220	72.5
200	16	500	340	160	12 X 22	268	30	255	105
250	16	600	405	180	12 X 26	320	32	240	113
200	10	500	340	210	8 X 22	268	26	255	105
250	10	600	395	240	12 X 22	320	28	310	140

Orseal Ltd, Lynstock Way, Lostock, Bolton, BL6 4QR

T: +44 (0)1204474300 / F: +44 (0)1204474347

E: sales@orseal.com

W: www.orseal.com