



the valve specialists

720TS Gas Approved Ball Valve



Description

- Full Bore
- Female to Female
- Steel Lever
- Firesafe
- Body material in nickel-plated, forged brass
- Suitable for fuel, gas, hot and cold water, compressed air, oil and hydrocarbons in general
- Temp -20° C to +130° C

No	Description	Material
1	Handle Lever	Zinc plated steel AI UNI5076
2	Self locking Nut	Zinc plated 8G Steel
3	Stem	Machined Brass Bar
4	O-rings	Elastomer
5	Thrust Washer	PTFE
6	End Adapter	Nickel Plated, forged brass
7	Ball Gaskets	PTFE
8	Ball	Machined brass bar, chrome-plated
9	Body	Nickel plated, forged brass

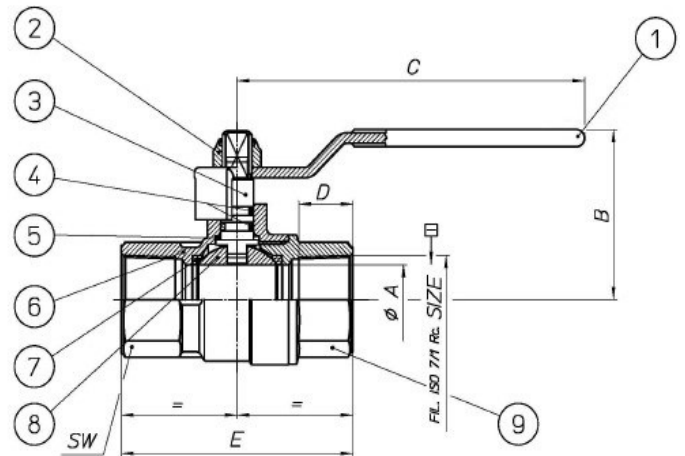

Additional Features

- T-Bar Handle
- Male x Female Connections

Standards

- Approved to the EN 331 Standard
- Screwed to UNI EN 10226 (BSPT on request)
- Top flange according to BS ISO 5211
- Pressure test to API 6D/API 598/BS EN12266-2

Size	1/4"	3/8"	1/2"	3/4"	1"	1.1/4"	1.1/2"	2"
Class rating	64	64	50	50	50	50	40	40
A (mm)	10	10	15	20	25	32	40	50
B (mm)	37	37	41	49.5	53.5	66	72	86
C (mm)	90	90	90	105	105	140	140	170
D (mm)	11	11.4	15	16.3	19.1	21.4	21.4	25.7
E (mm)	47.5	49.5	59.5	70	83	98.5	108	130
SW (mm)	17	21	25	31	38	47	54	66
Weight (kg)	138	151	204	346	533	987	1745	2456

Orseal Ltd, Lynstock Way, Lostock, Bolton, BL6 4QR

T: +44 (0)1204474300 / F: +44 (0)1204474347

E: sales@orseal.com

W: www.orseal.com