



the valve specialists

WRAS Ball Valves ORWBVT FF



Description

- Ideal to use with hot and cold domestic water applications, compressed air, oils and hydrocarbons in general
- Male to Female Threads
- Approvals WRAS, RoHS 2011/65/CE

No	Description	Material
1	Body	CW617N (EGM.001)
2	Pre-assembled Stem	Various
	Stem	CW614N (EGM.002)
	O-rings	NBR
	Thrust Washer	PTFE
3	Ball Gasket	PTFE
4	Ball Gaskets	CW617N (EGM.001)
5	End-Adapter	CW617N (EGM.001)
6	Red Lever	Steel
7	Self-Locking Nut	Steel

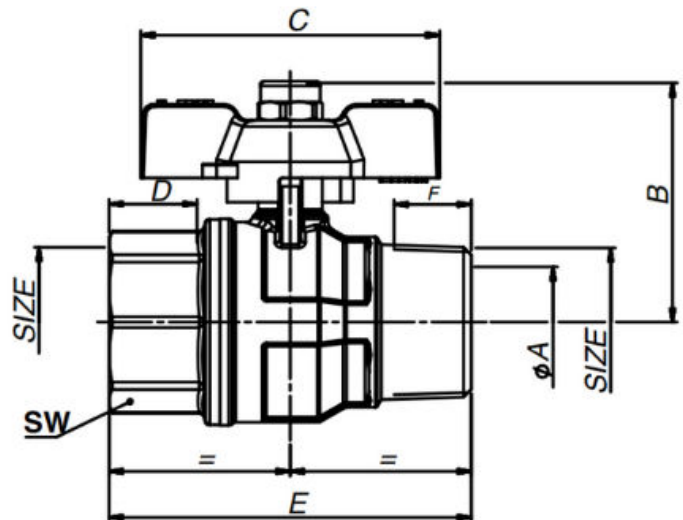

Size	1/4"	3/8"	1/2"	3/4"	1"	1.1/4"
ϕA pass./bore	8	10	15	20	25	32
B (mm)	29.4	30.4	40	42	52	59
C (mm)	52	52	52	52	65	65
D (mm)	11	11.4	15	16.3	19.1	21.4
E (mm)	53	54	55.5	64	78.5	88.5
F (mm)	9	10	13.2	14.5	16.8	19.1
SW (mm)	15/17	18/21	24	30	37	46

Orseal Ltd, Lynstock Way, Lostock, Bolton, BL6 4QR

T: +44 (0)1204474300 / F: +44 (0)1204474347

E: sales@orseal.com

W: www.orseal.com