



the valve specialists

Series 43 Spring Check Valve PN16



Key Features

- Class 200, PN16, PSI200
- Temperature range: -20 to 180 degrees Celsius
- Thread conforms with EN 10226-1M, ISO 7-1
- CE PED tested with test report 3.1 EN 10204
- Opening pressure 0.1-0.3 bar

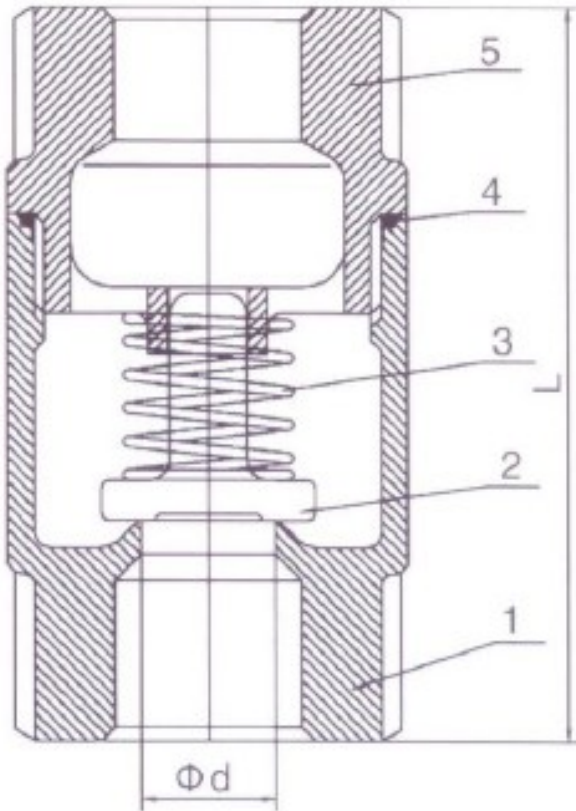

Size	DN	3/8"	1/2"	3/4"	1"	1.1/2"	2"
d	10	15	20	25	32	40	50
L	55	55	60	70	80	85	100

No.	Description	Material
1	Body	CF8M
2	Disc	CF8M
3	Spring	304/316
4	Joint Gasket	PTFE
5	Cap	CF8M

Orseal Ltd, Lynstock Way, Lostock, Bolton, BL6 4QR

T: +44 (0)1204474300 / F: +44 (0)1204474347

E: sales@orseal.com

W: www.orseal.com